

INSTALLATION

MECHANICAL

The Model S81 is best mounted horizontally at the point where an alarm or control signal is required.

The thread should be tightened to a torque not exceeding 22Nm (16.2 lbf.ft)

Absolute Maximum Ratings

Supply Voltage	7-35Vdc
Supply Current	1.5mA + source output
Load Current	1.0A (Sink) or 20mA (Source)
Pressure	5.0 Bar (72psi)
Temp. range: Fluid:	-40°C to +130°C
Storage:	-50°C to +140°C

Other Parameters

Sealing	IP67
Fluid types	Water based fluids compatible with Brass, PTFE and NBR rubber
Alarm Delay	0 - 25s rising or falling (Factory set)
Weight	0.053 kg

ELECTRICAL

Example wiring diagram

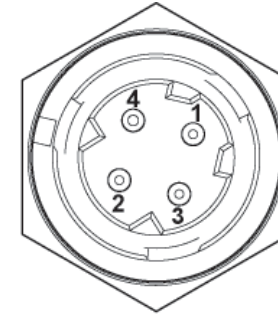

4: Output 2	Source 5V or V+
2: GND	Negative power supply or GND
1: V+	Positive power supply
3: Output 1	Transistor switched to GND (Sink)
Body	Not connected

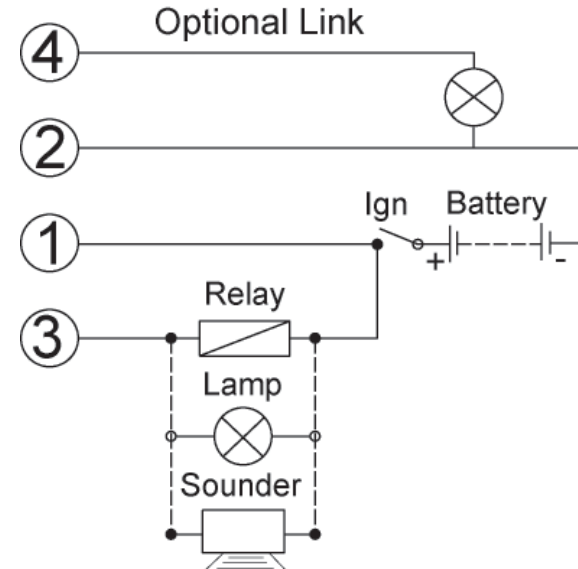



INSTALLATION INSTRUCTIONS

Model S81 Liquid level switch

Fozmula Limited

Berrington Road, Leamington Spa, Warwickshire, CV31 1NB, UK

Tel: +44 (0)1926 466700 Fax: +44 (0)1926 450473

Email: sales@fozmula.com web: www.fozmula.com